

# CLARKE®

## LANDSCAPER



**SELF PROPELLED LAWNMOWER**  
**MODEL NO: CSP56LME**

PART NO: 2345685

### ASSEMBLY & USER INSTRUCTIONS

UK  
CA | CE



ORIGINAL INSTRUCTIONS

GC11/25

---

## **INTRODUCTION**

---

Thank you for purchasing this CLARKE Lawnmower.

Before attempting to use this product it is essential that you read this manual thoroughly and carefully follow all instructions given. In doing so you will ensure the safety of yourself and that of others around you, and you can also look forward to the product giving you long and satisfactory service.

If however, having followed the instructions in this booklet carefully, you encounter problems, take the unit to your local CLARKE dealer.

Ensure that all components are present. Should any loss or damage be apparent, please contact your CLARKE dealer immediately.

Please keep these instructions in a safe place for future reference.

---

## **GUARANTEE**

---

This CLARKE product is guaranteed against faulty manufacture for a period of 12 months from the date of purchase. Please keep your receipt as proof of purchase.

This guarantee is invalid if the product is found to have been abused or tampered with in any way, or not used for the purpose for which it was intended.

Faulty goods should be returned to their place of purchase, no product can be returned to us without prior permission.

This guarantee does not effect your statutory rights.

---

## **ENVIRONMENTAL PROTECTION**

---

Do not dispose of this product or associated components with general household waste. All tools, accessories and packaging should be sorted, taken to a recycling centre and disposed of according to the laws governing Waste Electrical and Electronic Equipment.

Through the purchase of this product, the customer is taking on the obligation to deal with the WEEE in accordance with the WEEE regulations in relation to the treatment, recycling & recovery and environmentally sound disposal of the WEEE. In effect, this means that this product must not be disposed of with general household waste. It must be disposed of according to the laws governing Waste Electrical and Electronic Equipment (WEEE) at a recognised disposal facility.

Always dispose of oil and petrol in an manner which is compatible with the environment. Never pour oil or petrol into drains. Contact your local recycling centre for advice on the disposal of oil and petrol.

## SPECIFICATION

|                            |                         |
|----------------------------|-------------------------|
| Model                      | CSP56LME                |
| Part number                | 2345685                 |
| Dimensions L x W x D       | 1520 x 550 x 1050 mm    |
| Weight (empty)             | 35.5kg                  |
| Engine                     | SRV225                  |
| Power                      | 4.4 kW                  |
| Speed of rotation          | 3600 rpm                |
| Fuel type                  | Petrol                  |
| Oil capacity & type        | 0.45L (SAE 10W/30)      |
| Fuel tank capacity         | 1.2 L                   |
| Fuel consumption (max rpm) | 1.4 L/hr                |
| Running time @100% load    | 1 hr                    |
| Spark plug type            | F7RTC                   |
| Width of cut               | 56cm                    |
| Cutting height range       | 25-75mm (7 adjustments) |
| Collection capacity        | 65L                     |
| Drive speed                | 1m/s                    |
| Battery charging time      | 1 hr                    |
| Charger input voltage      | 230V ~ 50HZ             |
| Battery voltage & output   | 18V ~ 2.0 Ah            |
| Rounded sound power level  | 98 dB                   |
| Vibration                  | 5.5850 m/s <sup>2</sup> |

---

## GENERAL SAFETY PRECAUTIONS

---

**WARNING: AS WITH ALL MACHINERY, THERE ARE CERTAIN HAZARDS INVOLVED WITH ITS OPERATION AND USE. EXERCISING CAUTION WILL REDUCE THE RISK OF PERSONAL INJURY.**

**WARNING: CERTAIN INTERNAL COMPONENTS OF THIS MACHINE CONTAIN LEAD IN SMALL QUANTITIES.**

### GENERAL SAFETY POINTS

1. If not used properly, this lawnmower can be dangerous and can cause serious injury to the operator or others. The operator is responsible for following the warnings and safety instructions in this manual and displayed on the lawnmower. The warnings and safety instructions **MUST** be followed to ensure reasonable safety and efficiency when in use.
2. **NEVER** allow children or people unfamiliar with these instructions to use the lawnmower. Local regulations may restrict the age of the operator.
3. **NEVER** operate the lawnmower when you are tired, ill or under the influence of alcohol, drugs or medication.
4. **ALWAYS** wear suitable clothing and footwear.
5. Only use the lawnmower in the manner and for the functions described in these instructions.
6. The operator or user is responsible for accidents or hazards occurring to other people or their property.

### SAFETY IN USE

1. **NEVER** operate the lawnmower in a confined space where exhaust fumes (carbon monoxide) can collect.
2. **NEVER** attempt any maintenance on your lawnmower while the engine is hot.
3. **NEVER** put hands near the grass discharge chute whilst engine is running.
4. **NEVER** use the mower unless the grass box is in position or the guard flap is closed.
5. **NEVER** pick up or carry the lawnmower while the engine is running.
6. **NEVER** walk backwards when mowing in case of tripping.
7. **NEVER** cut grass by pulling the mower towards you.
8. **NEVER** tamper with the engine settings which are pre-determined by the manufacturer.

9. **ALWAYS** stop the engine before pushing the mower across surfaces other than grass and when transporting the lawnmower to and from the area to be mowed.
10. **ALWAYS** reduce the throttle setting during engine shut down and turn off the fuel valve at the conclusion of mowing.
11. **ALWAYS** start the mower carefully with your feet well away from the blades, ensuring that the mower is level.
12. **ALWAYS** keep the lawnmower on the ground when mowing. Tilting or lifting the lawnmower may cause stones to be thrown out.
13. **ALWAYS** avoid using your lawnmower on wet grass wherever possible.
14. **ALWAYS** use the lawnmower in daylight or good artificial light.
15. **ALWAYS** stop the engine and wait until the blade has stopped, before leaving the mower unattended for any period or when re-fuelling.
16. **ALWAYS** stop the engine and wait until the blade has stopped:
  - before clearing a blockage.
  - before checking, cleaning or working on the mower.
  - if you hit an object. (**DO NOT** use your lawnmower until you are sure that the entire lawnmower is in a safe operating condition).
  - if the lawnmower starts to vibrate abnormally check it immediately.
17. Mowing on banks and slopes can be dangerous. **DO NOT** mow on banks or steep slopes of more than 15 degrees. Mow across the face of slopes, rather than up and down.
18. Beware of injuring toes or hands. **DO NOT** put hands or feet near a rotating blade.

## **FUEL SAFETY**

### **WARNING: PETROL IS HIGHLY FLAMMABLE**

1. Store fuel in a cool place in a container specifically designed for the purpose. In general, plastic containers are unsuitable.
2. Refuel outdoors only and do not smoke while re-fuelling.
3. Add fuel **BEFORE** starting the engine. **NEVER** remove the cap of the fuel tank or add fuel while the engine is running or when the engine is hot.
4. If petrol is spilled, **DO NOT** attempt to start the engine but move the machine away from the area of spillage and avoid creating any source of ignition until petrol vapours have dissipated.
5. Replace all fuel tank and container caps securely.
6. Move the lawnmower away from the fuelling area before starting.

## LITHIUM-ION BATTERY USE AND CARE (ELECTRIC START)

1. Only use with the battery pack supplied. Use of any another battery pack may create a risk of injury and fire.
2. **DO NOT** charge the battery when the room temperature is below 10°C. **DO NOT** store the battery where the temperature may exceed 40°C (104°F)
3. When the battery pack is not in use, keep it away from metal objects that could make a connection from one terminal to another. Shorting the battery terminals together may cause burns or a fire.
4. Dispose of spent batteries correctly as they contain Lithium-ion. They are re-cycleable and should be taken to a recycling centre to be disposed of as stipulated by local regulations. **DO NOT** incinerate battery as it may explode when exposed to fire. **DO NOT** attempt to open, disassemble, modify or service a battery pack.
5. Handle batteries so as to avoid damage, fire, corrosion or personal injury.
6. **NEVER** crush, puncture, short external contacts or dispose of in fire or water.
7. **NEVER** attempt recharging the battery by means of an engine generator or a DC power source.
8. **NEVER** allow a leaking battery to contact your person. If you come into contact with battery liquid take the following immediate action:
  - In case of skin contact, wash immediately.
  - In case of eye contact, wash with a strong solution of boric acid and seek immediate medical attention.





---

## SAFETY SYMBOLS

---





### LAWNMOWER

The full technical specification of the lawnmower is printed on a label on the machine. The meanings of the markings and symbols are shown below

|   |  |   |   |
|---|--|---|---|
|  | Read instruction manual before use           |  | Wear ear protection when using this product |
|  | Wear eye protection when using this product. |  | Wear protective footwear                    |

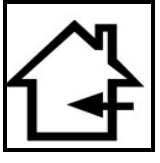
## BATTERY CHARGER

The full technical specification of the battery charger is printed on a label on the charger. The meanings of the markings and symbols are shown below

|   |   |   |                                       |
|---|---|---|---------------------------------------|
|  | Read instruction manual before use                            |  | Charging pack for indoor use only     |
|  | Harmful to aquatic life                                       |  | Do not incinerate (Battery pack only) |
|  | WEEE directive compliance required for Lithium-Ion batteries. |  | Do not immerse in any liquid          |

## LIST OF ITEMS SUPPLIED

The machine is delivered with the following components:

- Upper handlebar with fixings (connected by cables)
- Lower handlebar
- Tool kit containing spark plug spanner/tommy bar and open spanner
- Grass Collection Box/ bag assembly
- Grass discharge chute (fitted)
- Blanking plate
- Side discharge duct
- Fixings pack (bolts/washer/nuts)
- Engine starting battery
- Battery charging unit

# OVERVIEW

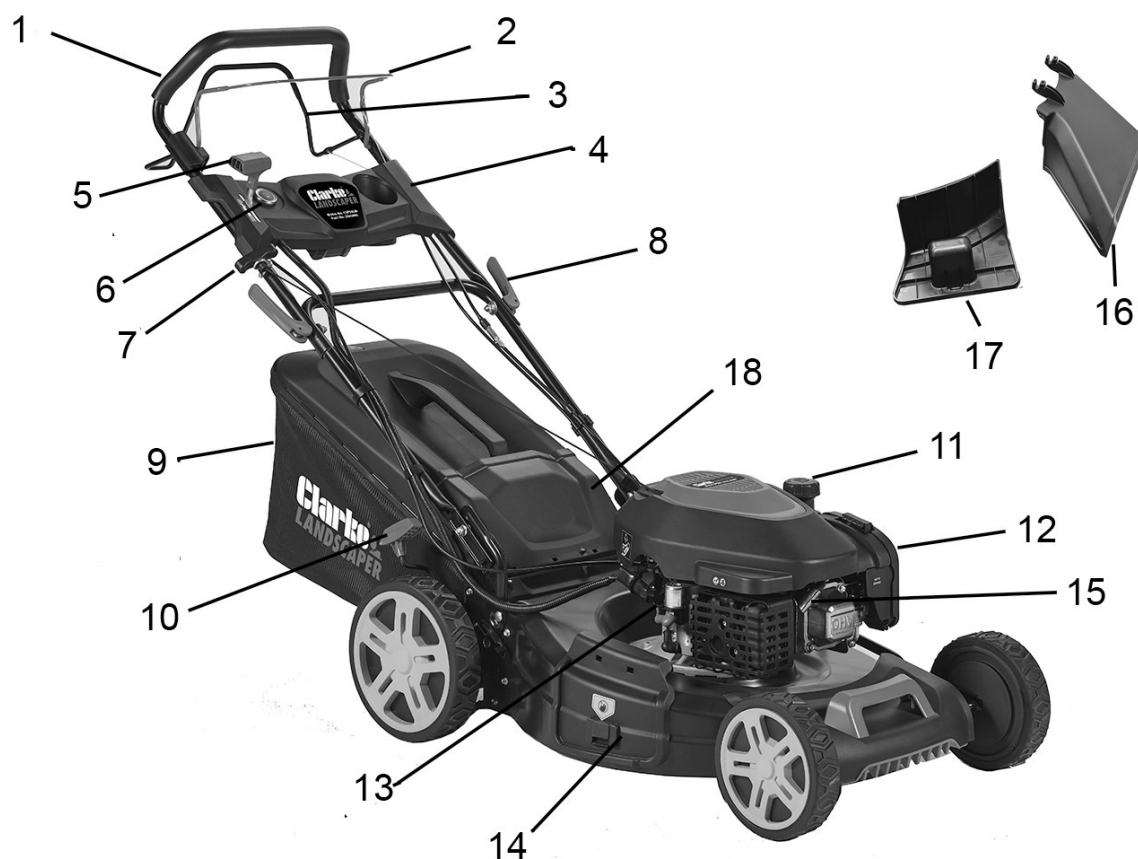

|   |                             |
|---|-----------------------------|
| 1 | Upper handlebar             |
| 2 | Driving Lever               |
| 3 | Engine brake lever          |
| 4 | Panel with battery assembly |
| 5 | Engine speed control lever  |
| 6 | Starting button             |
| 7 | Starter pull-cord handle    |
| 8 | Quick release handle        |
| 9 | Grass collection box/bag    |

|    |                                 |
|----|---------------------------------|
| 10 | Cutting height adjustment lever |
| 11 | Fuel filler cap                 |
| 12 | Inlet air filter housing        |
| 13 | Oil filler and dipstick         |
| 14 | Side discharge outlet flap      |
| 15 | Spark plug                      |
| 16 | Side discharge duct             |
| 17 | Blanking Plate                  |
| 18 | Guard flap                      |

# ASSEMBLY

## UPPER & LOWER HANDLEBARS

1. Attach the lower handlebars to the frame brackets with the bolts, washers & nuts provided. Note that the handlebars can be set at one of two angles by selecting either hole for the bolts.
2. Connect the upper handlebars to the lower handlebars using the bolts and plastic locking handles. Lock in the operating position.
3. If wished, pull the starter 'Pull Cord', until you can locate it in the pull cord attachment ring on the handlebar where it is ready to use.

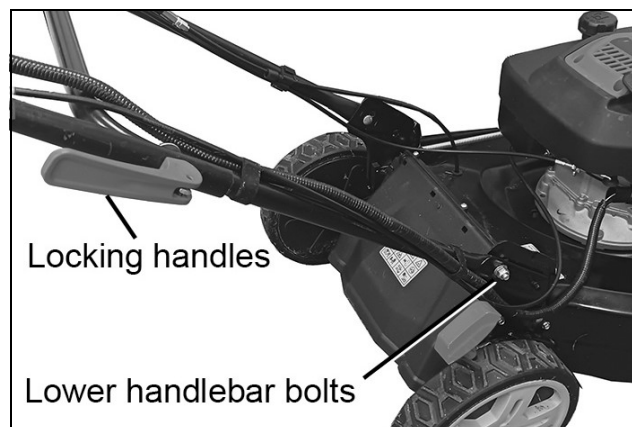

## INSTALLING THE GRASS COLLECTION BOX

1. To attach the grass collection box, lift the guard flap and hook the grass bag frame onto the cutter housing. Release the guard to secure the grass box in place.
2. Ensure the grass collection box is securely located.
3. To remove, raise the flap, grasp the grass box handle and lift away.



**NOTE:** Where grass collection is not required you can use the mower without the grass box but **MUST ENSURE THE GUARD FLAP IS FULLY CLOSED.**

## BLANKING PLATE & SIDE DUCT INSTALLATION

1. Lift the rear cover and clip the Blanking Plate onto rear discharge outlet and clip into place.
2. Lower the rear discharge cover.
3. Lift the side flap against the resistance of the spring until high enough to introduce the side duct.

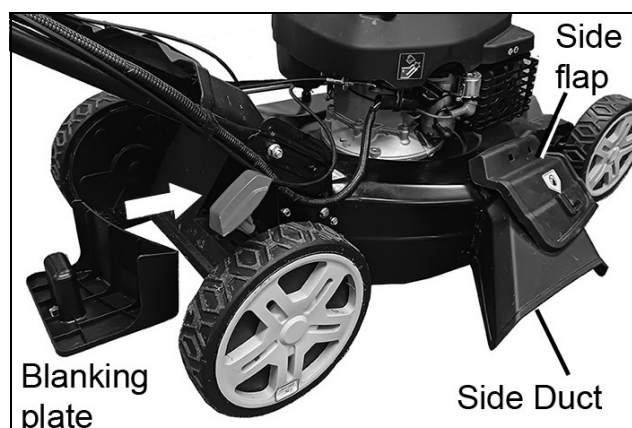

Clip this into place underneath the side flap to achieve side discharge of the grass cuttings from the machine.

Assembly is now complete, but before using the lawnmower, certain important checks **MUST** be made which are described in the following pages.

## ENGINE OIL

**IMPORTANT: THE ENGINE IS SUPPLIED WITHOUT OIL DURING SHIPMENT. ENSURE THE ENGINE IS FILLED WITH THE CORRECT AMOUNT OF A SUITABLE OIL BEFORE STARTING THE ENGINE.**

**Serious damage may result if the engine is run without oil.**

1. To fill with oil, remove the oil filler cap and fill to the MAX mark on the dipstick, using a good quality CLARKE SAE10W/30 4-stroke oil (part no; 3050845) not supplied).
2. Change the oil after the first five hours operation of a new mower (see Maintenance), and thereafter every 25 working hours.
3. **ALWAYS** change the oil while the engine is warm - but not hot. **NEVER** attempt any maintenance on a hot engine.
4. When checking the oil level, always clean around the dipstick before unscrewing it. Once removed, wipe it with a clean cloth then replace, screwing down fully. Remove once more and check the level.
5. Get into the habit of checking the oil level before each use.

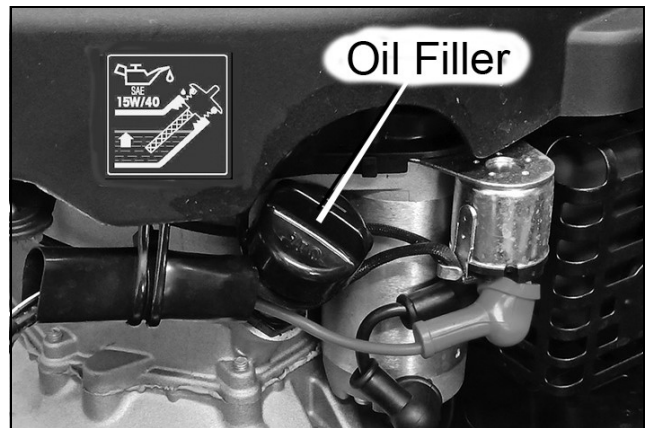

## FUEL (PETROL)

**WARNING: PETROL IS HIGHLY FLAMMABLE**

1. Fill the fuel tank with regular grade unleaded petrol.
2. **DO NOT** fill or refuel when the engine is hot.
3. **DO NOT** fill the fuel tank whilst smoking or near naked flame.
4. **DO NOT** remove the fuel filler cap whilst the engine is hot or running. **ALWAYS** allow the engine to cool for at least 2 minutes before re-fuelling.

5. To avoid introducing dirt into the fuel system, wipe all grass and dirt from the petrol filler cap before unscrewing it.

6. It is recommended that you fill the tank through a funnel with a filter.

7. Wipe away any spillages before starting.

8. Use fresh petrol. Stale fuel can cause the carburettor to clog up.

9. **DO NOT** refuel indoors or in an unventilated area.

10. **DO NOT** operate engine if petrol has been spilled. Move lawn mower well away from the scene before starting.



## CHARGING THE STARTING BATTERY

The battery will have been shipped in a low charge state and will require charging before use.

1. Press the battery release clip on the end of the battery pack and disengage the battery pack from the lawnmower.

2. Plug the charger into a 230V power supply and switch ON.

- The green POWER ON light will illuminate to show the unit is connected to the mains supply.

3. Engage the battery pack with the battery charger, noting that it will only fit one way.

- The red light will come on to indicate the battery is charging.

- When charging is complete (typically after about approx 1 hour), the GREEN charging light comes on. The battery pack can be considered charged and be removed. The charging time will be dependent upon the initial state of the battery.

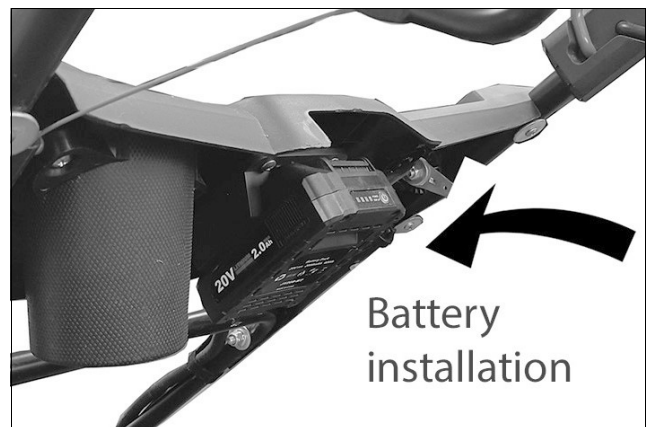

- When charging a new battery pack it may initially not accept full charge. This is common & does not indicate a fault. It can be recharged fully after it has been discharged a couple of times.
  - If charging does not take place, ensure all connections are clean.
4. After charging, switch off and unplug the charger from the power supply.
  5. Remove the battery pack from the charger and slide it back into the lawnmower until it clips into place.

The battery pack should slide in easily. If the battery pack is not to be fitted immediately, ensure that the metal contacts are protected so as to avoid the possibility of a short circuit which would cause damage. For maximum battery life, we recommend that you maintain the battery in a fully charged state at all times.

---

## STARTING & OPERATING

---

### USING THE CONTROLS

#### ENGINE BRAKE LEVER

Pull back the red engine brake lever before starting the engine. Release the engine brake lever to stop the engine.

- If keeping the red engine brake lever released, the starter rope will not pull out due to the flywheel brake.

Holding the engine brake lever and handlebar continuously will keep the engine and blade rotating. When releasing the engine brake lever, the engine will stop running and the blade will stop rotating.

- When you need to stop work, release the engine brake lever to stop the engine.

#### DRIVING LEVER

The driving lever controls the transmission via cables to disengage and engage in order to drive /stop the rear wheels.

Hold the black driving lever and the lawnmower will move forward. Release the driving lever and the lawnmower will stop.

#### CAUTION

- Release the driving lever before starting the engine. If holding the driving lever, the mower will move forward when you pull the starter handle.
- When operating the driving lever, keep it either fully released or fully held. Action should be prompt and continuous.

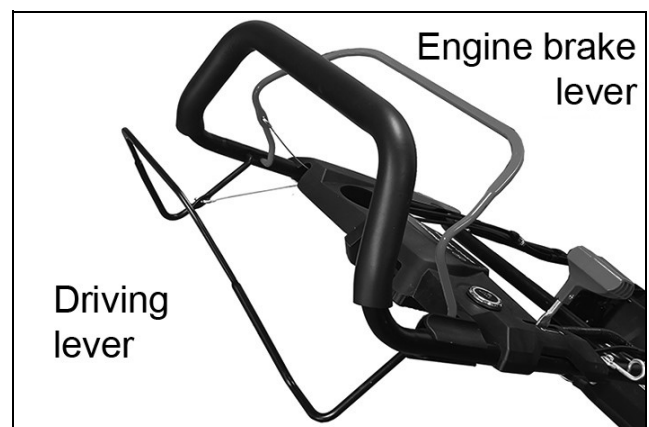

- When you choose to operate the lawn mower in self-propelled mode, just hold the driving lever continuously. It can give longer life to the clutch.

## STARTING THE ENGINE - MANUAL START

1. Release the driving lever. If the driving lever is held during starting the mower will move forward.
2. Stand at the operating position behind the lawnmower and hold the brake lever against the handlebar.
3. Allow the cord to recoil slowly, then pull the handle firmly towards you to its full extent to start the engine. You may need to do this more than once. Pull the starting rope slightly until you feel the resistance of the engine and pull the rope smartly. The engine should start.

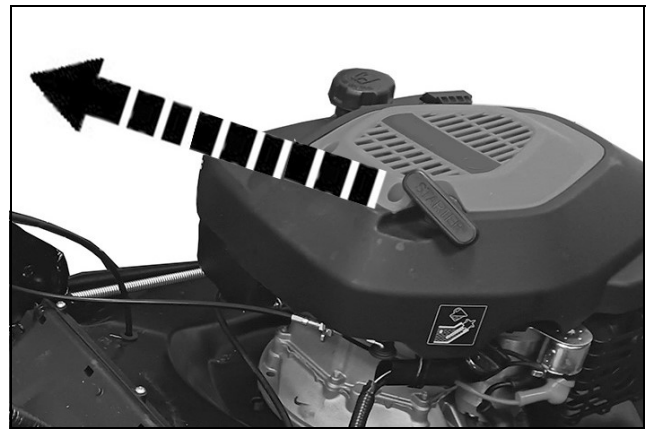

- **THE BLADE WILL BE ROTATING AS SOON AS THE ENGINE IS RUNNING.**

It is easier to start the engine on clean or cut lawn where the blade can rotate freely.

## STARTING THE ENGINE - ELECTRIC START

1. Stand at the operating position and hold the engine brake lever together with the handlebar.
  2. Press the START button on the cross beam and the engine should start.
- The blade will rotate when the engine is started.
3. Keep holding the brake lever until ready to move off and begin work.

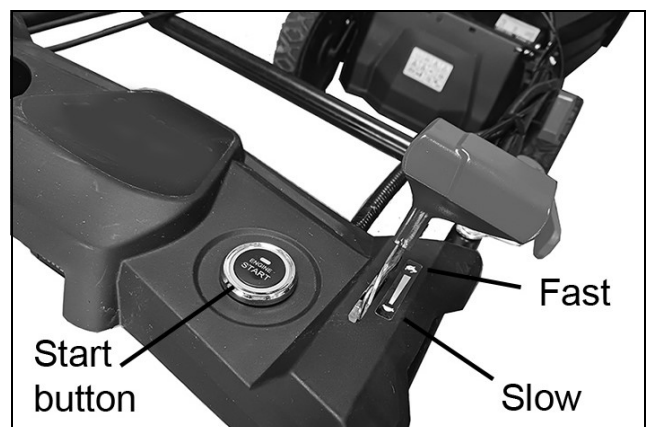

## ENGINE RUNNING

1. Move the control lever to the "Fast" position to increase the engine speed and the "Slow" position to slow down.
2. Once started, gently move the self-propelled drive lever towards the handle, thereby engaging the drive. **ALWAYS** start the engine with the drive disengaged.
3. Releasing the power-drive control lever stops the drive to the rear wheels. To stop the mower, - release the power-drive control lever, then adjust the throttle lever.

## CUTTING HEIGHT ADJUSTMENT

By moving the adjustment lever, the chassis height of the lawn mower can be adjusted to change the cutting height.

1. Move the adjustment lever rearward to raise the cutting height.
2. Move the adjustment lever forward to lower the cutting height.

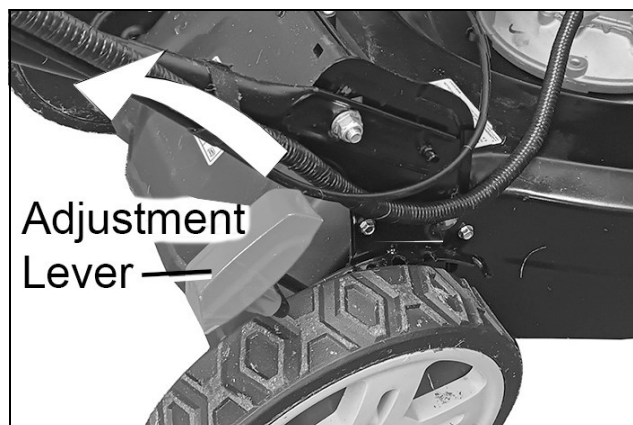

---

## USING THE MOWER

---

**DO NOT** overload your lawnmower. Correct height adjustment will help reduce engine overload and will help prevent damage to your lawnmower.

Starting the mower on clear, level ground will be easier where the blade can rotate freely.

Avoid steep slopes of more than 15 degrees, especially if the grass is damp as this could cause you to slip and lose control of the mower.

Set the height of cut by pulling the adjustment lever away from the location slots and moving to the selected position.

1. When mowing long thick grass, set the cutting height to its highest setting and lower with each successive cut.
2. Start mowing from the outside edge of the lawn, mowing in strips in alternate directions, overlapping slightly.
3. Mow twice a week in the growing season. Your lawn will suffer if more than one third of its length is cut at one time and this may also result in poor grass collection.
4. **ALWAYS** make sure the lawn is clear of debris which could be thrown up by the blade.
5. Before use, always visually inspect to see that blades are not worn or damaged. Replace worn or damaged blades before mowing.

### SLOPES

Mow across slopes, not up and down. Avoid steep slopes (more than 15°), and be careful when changing direction. Mowing on a slope when the grass is damp or wet could cause you to slip, fall, and lose control of the mower.

## **CUTTING HEIGHT**

1. Consult a local nursery or garden centre for cutting height recommendations and advice about specific types of grasses and growing conditions in your area.
2. If you look closely, you'll see that most grass has stems and leaves. If you cut off the leaves, you'll scalp the lawn.
3. Let the grass recover between mowing. Your mower will work better and your lawn will look better.
4. If your grass gets too tall, cut it once at the highest cutting height setting, then mow again in 2 or 3 days. Don't take off more than one third of total grass height in any one mowing session or brown patches may develop.

## **CUTTING WIDTH**

For an even lawn finish, overlap each mowing swath by approximate 5-10cm. If the grass is very tall or thick, use more overlap and a narrower mowing swath.

## **BLADE SPEED**

The blade must spin very fast to cut properly. Always use the HIGH throttle setting and keep the engine running at maximum rpm. If engine speed drops, it could mean the engine is being overloaded by the blade trying to cut too much grass. Mow a narrower swath, move the mower slower, or raise the cutting height.

## **BLADE SHARPNESS**

A sharp blade cuts cleanly. A dull blade tears the grass, leaving shredded ends that turn brown. When your blade doesn't cut cleanly anymore, have it sharpened or replaced.

## **DRY GRASS**

If the ground is too dry, mowing will stir up a lot of dust. Besides being unpleasant to work in, too much dust will clog the carburettor air filter. If dust is a problem, water your lawn the day before mowing. Mow when the grass is dry to your touch, but the soil is still moist.

## **WET GRASS**

Wet grass is slippery and can make you lose your footing. Also, wet grass clippings will clog the cutter housing and collect in clumps on the lawn. Always wait for wet grass to dry before mowing.

## **FALLEN LEAVES**

When equipped with the grass bag, your mower can be used to pick up fallen leaves for disposal. If using the mower to bag large amount of fallen leaves and not for mowing, set the cutting height adjustment lever at highest setting.

If you want to mulch fallen leaves into your lawn, don't let the leaf cover get too deep before you begin. For best results, start mulching while grass still shows through the

leaf cover. In places where fallen leaves completely cover the grass remove the leaves by raking, or install a grass bag, so your mower can pick them up for disposal.

### **CLOGGED CUTTER HOUSING**

Before clearing a clogged cutter housing, stop the engine and tilt the mower so the carburettor side is up. Clear a clogged deck with a stick or blade.

---

## **AFTER USE AND STORAGE**

---

Proper storage preparation is essential for keeping your mower trouble-free and looking good. The following steps will help to keep rust and corrosion from impairing your mower's function and appearance and will make the engine easier to start when you use the mower again.

1. **NEVER** store the lawnmower with fuel in the tank inside a building where fumes can reach an open flame or spark.
2. Allow the engine to cool before storing the mower in a small enclosure.
3. To reduce fire hazard, keep the engine assembly and fuel storage area free of grass and leaves.
4. If the fuel tank has to be drained, this should be done outdoors.
5. Be careful of the sharp cutting blade during maintenance work.

### **CLEANING**

Wash the lawn mower, including the underside of the cutter housing. Wash the engine by hand and be careful to prevent water from entering the air cleaner and/or muffler

**CAUTION: USING A GARDEN HOSE OR PRESSURE WASHING EQUIPMENT CAN FORCE WATER INTO THE AIR CLEANER. WATER IN THE AIR CLEANER WILL SOAK THE FILTERS AND CAN ENTER THE CARBURETTOR OR ENGINE, CAUSING DAMAGE.**

**CAUTION: WATER ON A HOT ENGINE CAN CAUSE DAMAGE. IF THE ENGINE HAS BEEN RUNNING, ALLOW IT TO COOL FOR AT LEAST 30 MINUTES BEFORE WASHING.**

If using a garden hose or pressure washing equipment to clean the cutter housing, be careful to avoid getting water into controls and cables, or anywhere near the engine air cleaner or muffler opening.

## FLUSHING WITH THE HOSE CONNECTOR

1. Connect the hose onto cleaning nozzle and turn on the water switch to wash the chassis.
2. Start the engine and let the blades run at normal working speed for a few minutes (wash it on the grass or other suitable places).
3. **DO NOT** allow water or washed debris to enter a clean water source.



## MANUAL CLEANING

1. If there are still debris after washing, use a plastic brush or cloth to clean it.

## AFTER CLEANING

1. After cleaning, remove the hose and dry the surface of the lawn mower.
2. Stand the mower back on its wheels outdoors and start the engine until it reaches normal working temperature to evaporate residual moisture.
3. Turn off the engine and allow it to cool down.
4. After cleaning the lawn mower, let it dry. If necessary, repair the paint surface and apply a thin layer of anti-rust oil to any parts that may rust.

## FUEL

Petrol will oxidise and deteriorate in storage. Old petrol will cause hard starting and it leaves gum deposits that clog the fuel system. If the fuel in your mower deteriorates during storage, you may need to have the carburettor and other fuel system components serviced or replaced.

The length of time that fuel can be left in your fuel tank and carburettor without causing functional problems will vary with such factors as fuel blend, storage temperatures and whether the fuel tank is partially or completely filled. The air in a partially filled fuel tank promotes fuel deterioration. Very warm storage temperatures accelerate fuel deterioration. Fuel deterioration problems may occur within 30 days or even less if the fuel was not fresh when you filled the fuel tank.

The warranty does not cover fuel system damage or engine performance problems resulting from neglected storage preparation.

You can avoid fuel deterioration problems by draining the fuel tank and carburettor.

- Use fresh and clean fuel.
- To slow deterioration, keep fuel in a certified fuel container.
- If long term storage (<30 days) is foreseen, drain the fuel tank and carburettor.

## DRAINING THE FUEL TANK AND CARBURETTOR

1. Drain the fuel in the fuel tank and carburettor into a suitable container after releasing the spring clips securing the fuel tube connecting the tank and the carburettor.
2. Reconnect the tube once drained.

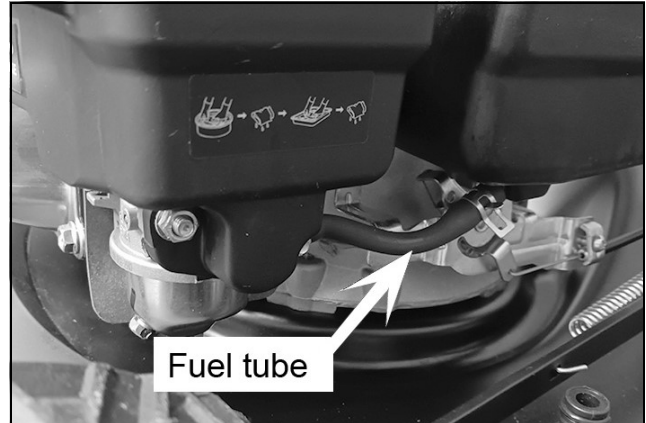

## LONG TERM ENGINE CYLINDER PROTECTION

1. Remove the spark plug (See page 20)
2. Pour a spoonfull of clean engine oil into the cylinder.
3. Pull the starter grip several times to distribute the oil in the cylinder. Reinstall the spark plug.
4. Pull the starter grip slowly until resistance is felt, then return the starter grip gently. This closes the valves so moisture cannot enter the engine.

---

# MAINTENANCE

---

## AFTER USE

To ensure the best performance from the lawnmower it should be kept clean. Always clean the lawnmower immediately after use so as not to allow grass cuttings and other debris to become dry and caked hard onto any of the internal surfaces. This will directly affect the cutting and grass collection performance.

Allow a period of time for the engine to cool before cleaning. Once the engine is cool, remove grass from under the machine with a brush. Make sure that the underside of the lawnmower deck is clean and clear of grass cuttings.

Ensure that the grass discharge chute and guard flap are clean and clear. The grass collection box must always be emptied after use and the interior cleaned and cleared of grass cuttings.

Make sure that the exterior of the engine is clear of all cuttings and dirt, especially around the silencer & air intake. Check the oil level.

Finally, wipe over the surface of your lawnmower with a dry cloth.

**NEVER** use solvents or chemical cleaners to clean your lawnmower.

Store your lawnmower in a cool, dry place where it will be protected from damage.

## AT THE END OF THE MOWING SEASON

1. Remove and sharpen the cutting blade or replace the blade if found to have been damaged by debris /stones etc (for blade removal see below).
2. Remove and clean the air filter.
3. Drain the petrol (see page 18).

## MAINTENANCE SCHEDULE

Follow the hourly or calendar intervals, whichever occurs first. More frequent service is required when operating in adverse conditions.

### AFTER FIRST 5 HOURS OF MACHINE USE

Change the engine oil (see page 20).

### EVERY 25 HOURS OR EVERY SEASON

Change the oil and clean the air filter (see pages 19/20).

## REPLACING THE BLADE

If the blade has worn excessively and has become pitted and blunt it should be replaced or sharpened.

**WARNING:** Take care that fuel does not escape from the tank when the machine is tipped over.

Turn the mower onto its side and remove the single bolt and penny washer securing the blade to the end of the drive shaft. Hold the blade securely while removing the bolt, taking care of any sharp edges.

- An 11/16" wrench will be required.

Replace the blade in reverse order, ensuring the lugs on the blade holder engage the blade before tightening the securing nut.

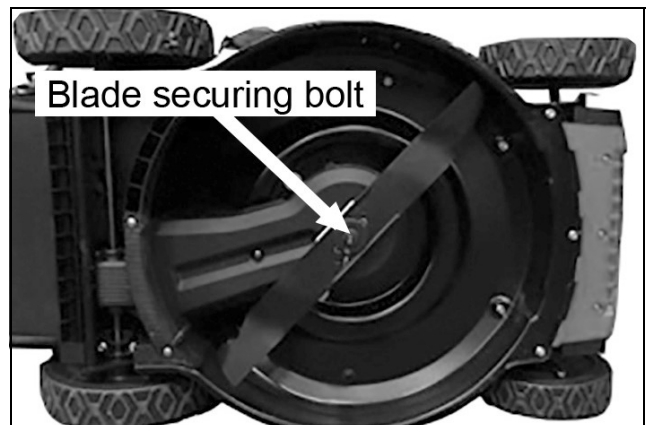

## CLEANING THE AIR FILTER

Dirty air cleaner will restrict air flow to the carburettor, reducing engine performance. If you operate the mower in very dusty areas, clean the air cleaner more often than specified in the MAINTENANCE SCHEDULE.

1. Release the clip at the top to remove the air cleaner cover.
2. Remove the sponge filter elements from the air cleaner housing and replace them if damaged.

**CAUTION: IF THE ENGINE IS RUNNING WITHOUT AN AIR FILTER ELEMENT OR THE FILTER ELEMENT IS DAMAGED, DUST WILL ENTER THE ENGINE, THEREBY ACCELERATING WEAR. SUCH DAMAGE IS NOT COVERED UNDER WARRANTY.**

3. Wash with soap and warm water, rinse and dry or wash with a non-flammable solvent and let it dry.
4. Wipe off the dirt in the air cleaner housing and cover with a damp cloth. Be careful not to let dirt pas beyond the housing.
5. Refit the sponge air filter parts and clip the cover back into place.

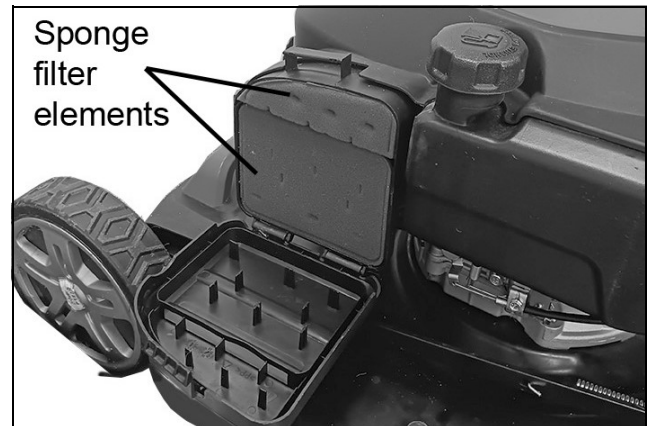

## **SPARK PLUG SERVICE**

- Recommended spark plug: F7RTC
1. Disconnect the spark plug cap and remove dirt from the area.
  2. Use the spark plug wrench supplied to remove the spark plug.
  3. Inspect the plug and replace if the electrode is worn, pitted, or if the insulator is cracked or chipped. Clean the plug completely if you are going to reuse it.
  4. Measure the spark plug gap with a suitable gauge. The gap should be 0.7 - 0.8 mm. Correct the gap, if necessary by bending the side electrode.
  5. Refit the spark plug carefully by hand, to avoid cross-threading. Tighten with the spark plug wrench to compress the washer.
  6. Refit the spark plug cap/lead to the spark plug.

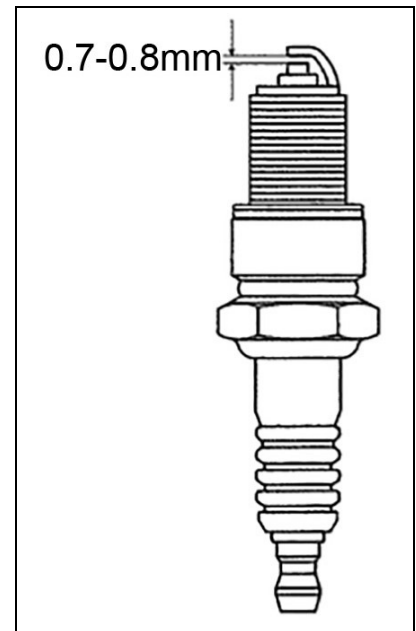

## **CHANGING THE OIL**

1. Turn the mower on its side and pour the oil into a suitable container. Warm oil will drain faster than when cold.
2. When completely drained, set the machine upright and replace the oil filler/dipstick. Refill with CLARKE SAE10W/30 oil (part no; 3050845) to the 'MAX' level on the dipstick.
3. **DO NOT** overfill. If overfilled, any excess oil can get transferred to the air cleaner housing and air cleaner. Screw in the oil filler cap/dipstick securely.
4. Dispose of old/spilled oil appropriately and wipe up any spillage.

## ENVIRONMENTAL PROTECTION

One of the most damaging sources of environmental pollution is oil products. **NEVER** throw away used engine oil with domestic refuse or flush it down a sink or drain. Collect any oil in a leak proof container and take it to your local waste disposal site.

## REPLACING THE DRIVE BELT

The self-propulsion system incorporates a drive belt which may after extensive use, require replacement.

1. Drain any remaining petrol from the lawnmower as described on page 18.
2. Turn the machine over and remove the cutting blade.
3. Remove the three screws holding the drive cover, and from above, pinch the retaining clip holding the cover to the machine body. Lift off the cover complete with the blade holder, sliding it off the drive shaft. The drive belt will now come away with the blade holder/driven pulley.

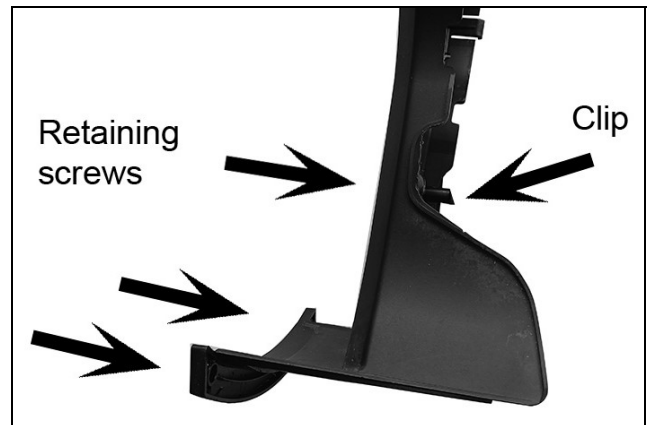

- The illustration shows the belt installed on the pulleys, complete with blade holder. The cover is absent to illustrate this.
4. Replace the defective drive belt and re-fit the blade holder and cover together, noting that a key (spline) engages the blade holder with the drive shaft. Press-fit the cover clip to the machine body and refit the three retaining screws

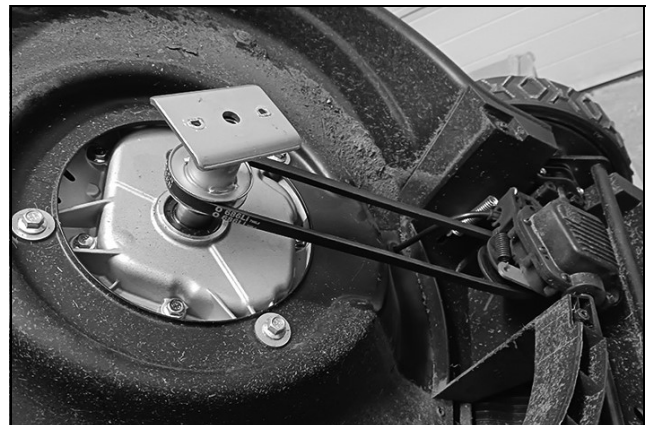

## GRASS BAG CLEANING AND REPLACEMENT

1. Wash the bag with a garden hose, and allow it to dry completely before use; a wet bag will clog quickly.
2. Replace a damaged bag with a genuine bag or its equivalent. Un-clip the plastic edges of the bag from the frame. Remove the bag from the frame.
3. Insert the frame into the new bag. Clip the plastic edges to the frame.

## ADJUSTMENTS

When the driving lever is released, the engine will stop. The engine will only run with the driving lever held against the main handle. All carburettor adjustments are factory set and will not need adjustment.

## **BATTERY DISPOSAL**

Dispose of old batteries in accordance with local authority regulations. **DO NOT** incinerate or crush, as this will increase the risk of explosion and contamination. If the battery contents come into contact with skin or the eyes, rinse with clean water for several minutes and seek medical advice immediately afterwards.

## **STORAGE**

If the lawnmower is stored for longer than a month, the fuel tank and carburettor should be drained to avoid the possibility of clogging up from fuel deposits. Ensure the engine is run until it stops for lack of fuel.

If a fuel additive is used, ensure the engine is run in order to distribute the additive to all parts of the fuel system before storage. The lawnmower may then be placed in long term storage.

---

# **FAULT FINDING**

---

## **ENGINE WILL NOT START**

1. Ensure engine speed control is in the start position.
2. Check that there is sufficient fuel in the tank.
3. Check the condition of the spark plug for cleanliness and correct gap.
4. Excess fuel flooding engine. Dry and reinstall spark plug. Start engine with throttle lever in FAST position.
5. Petrol may be stale, if so, replace.
6. Fuel filter clogged. Remove and clean filter before re-fitting.
7. Carburettor defect. Take machine to your dealer for repair.

## **LACK OF ENGINE POWER AND/OR OVERHEATING**

1. Check that the throttle lever is in the normal running position.
2. Disconnect the spark plug lead and allow the engine to cool down.
3. Clean grass clippings and debris from around the engine and air inlets and the underside of the machine including the discharge chute.
4. Clean the engine air filter thoroughly as shown on pages 19/20.
5. Petrol may be stale. If so, replace with fresh fuel.

## **EXCESSIVE VIBRATION**

1. Check that the blade is correctly fitted. If the blade is bent or otherwise damaged replace it with a new one.

2. If vibration persists, consult your local Clarke dealer or Clarke Service department.

## **POOR CUTTING QUALITY**

1. Unsuitable height setting. Adjust the cutting height to suit the length of grass especially if grass is too long.
2. Grass box full or clogged. Empty and clean out remaining material.
3. Chassis area clogged with damp grass etc. Shut down machine and clean out clogged material.
4. Blade is blunt or damaged. Sharpen or replace as necessary.

# HANDLEBAR COMPONENT PARTS

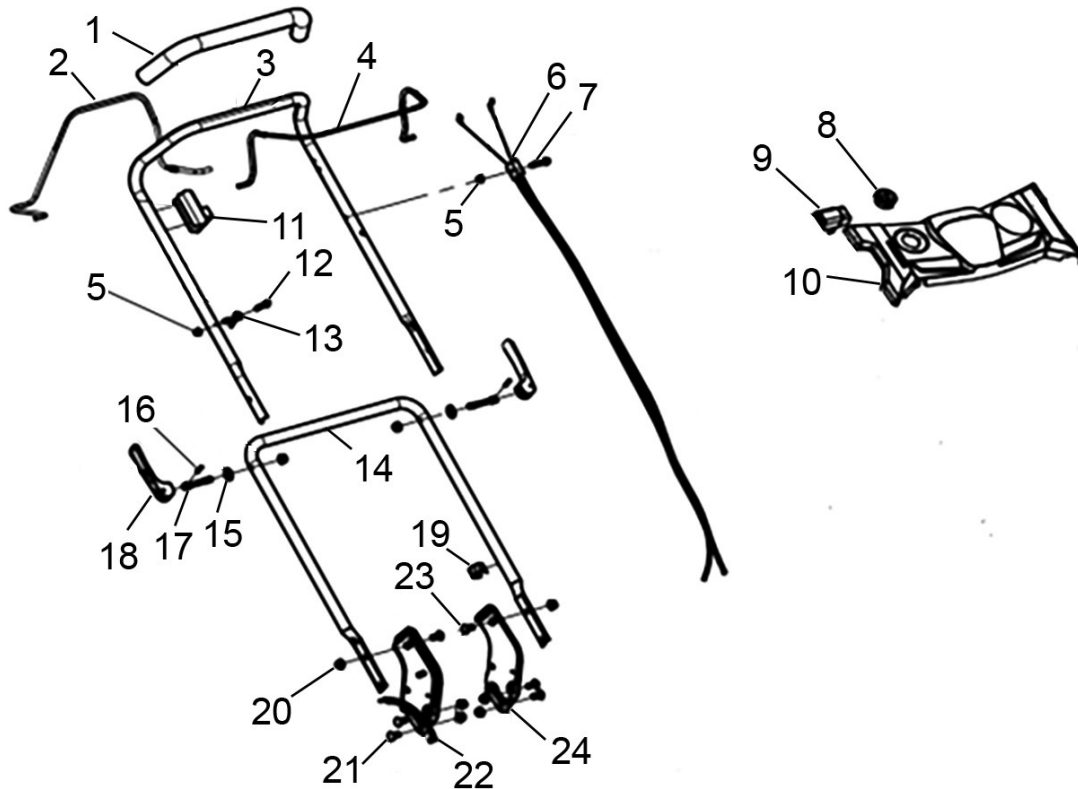

| No | Description              |
|----|--------------------------|
| 1  | Spongy Sleeve            |
| 2  | Driven Lever             |
| 3  | Handlebar                |
| 4  | Engine brake lever       |
| 5  | Hex nut                  |
| 6  | Cable Assembly           |
| 7  | Hex flange screw M6 x 35 |
| 8  | One-push start button    |
| 9  | Throttle handle          |
| 10 | Handlebar panel          |
| 11 | Lever limit block        |
| 12 | Hex flange screw M6 x 30 |

| No | Description           |
|----|-----------------------|
| 13 | Starting handle loop  |
| 14 | Lower handlebar       |
| 15 | Washer                |
| 16 | Elastic cylinder pin  |
| 17 | Fast lock screw       |
| 18 | Fast lock             |
| 19 | Wire clip             |
| 20 | Washer                |
| 21 | Cross head st screw   |
| 22 | Handlebar fixing seat |
| 23 | Carriage bolt         |
| 24 | Handlebar fixing seat |

# BODY COMPONENTS

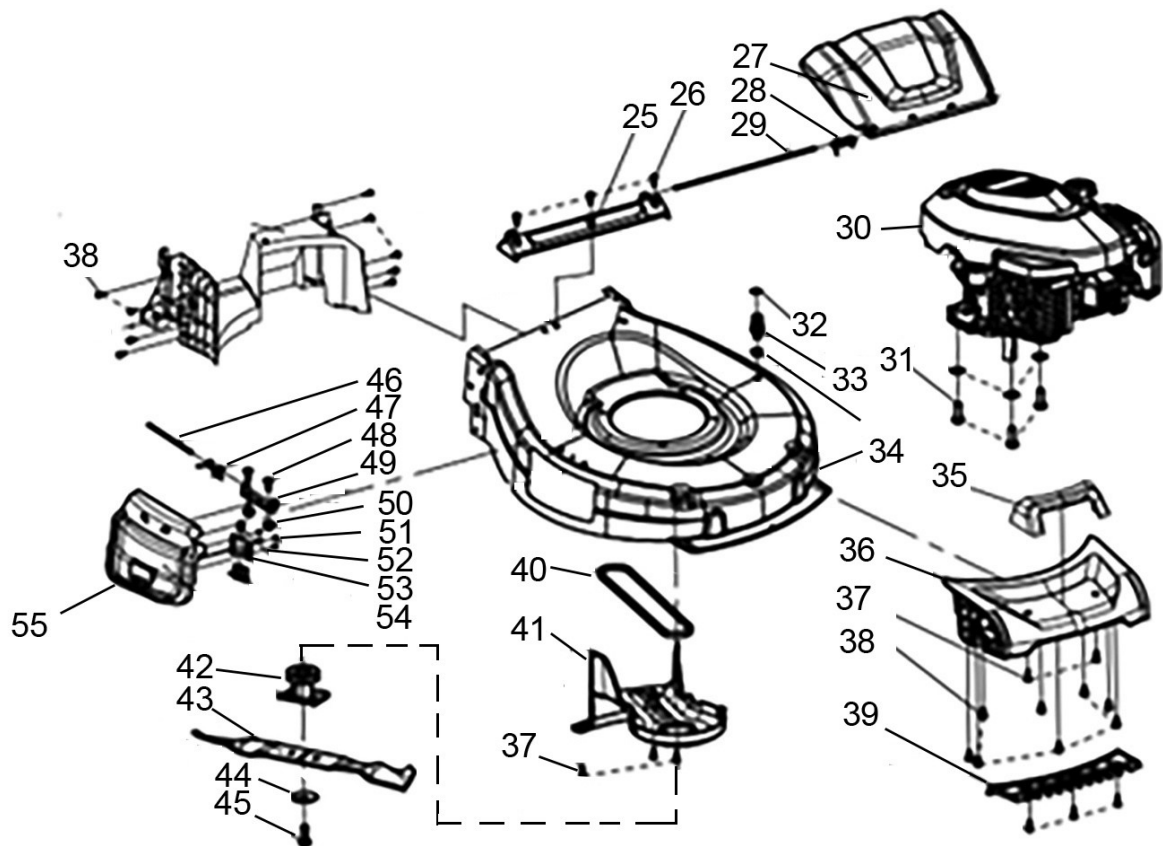

|    |                          |
|----|--------------------------|
| 25 | Rear cover bottom plate  |
| 26 | Cross head st screw      |
| 27 | Rear cover               |
| 28 | Rear cover spring        |
| 29 | Rear cover shaft         |
| 30 | Vertical shaft engine    |
| 31 | Hex flange screw M8 x 25 |
| 32 | O-ring                   |
| 33 | Washing plug             |
| 34 | Deck                     |
| 35 | Lifting handle           |
| 36 | Front decoration panel   |
| 37 | Cross head st screw      |
| 38 | Hex head st screw        |
| 39 | Grass comb               |
| 40 | Drive belt               |

|    |                                 |
|----|---------------------------------|
| 41 | Belt cover                      |
| 42 | Blade holder                    |
| 43 | Cutting Blade                   |
| 44 | Butterfly washer                |
| 45 | Hexagon screw                   |
| 46 | Side discharge shaft            |
| 47 | Side discharge chute spring     |
| 48 | Square neck screw               |
| 49 | Side discharge holder           |
| 50 | Hex flange nut M6               |
| 51 | Cross head st screw             |
| 52 | Side discharge chute spring     |
| 53 | Side discharge chute lock plate |
| 54 | Side discharge chute lock       |
| 55 | Side discharge cover            |

# AXLE COMPONENTS

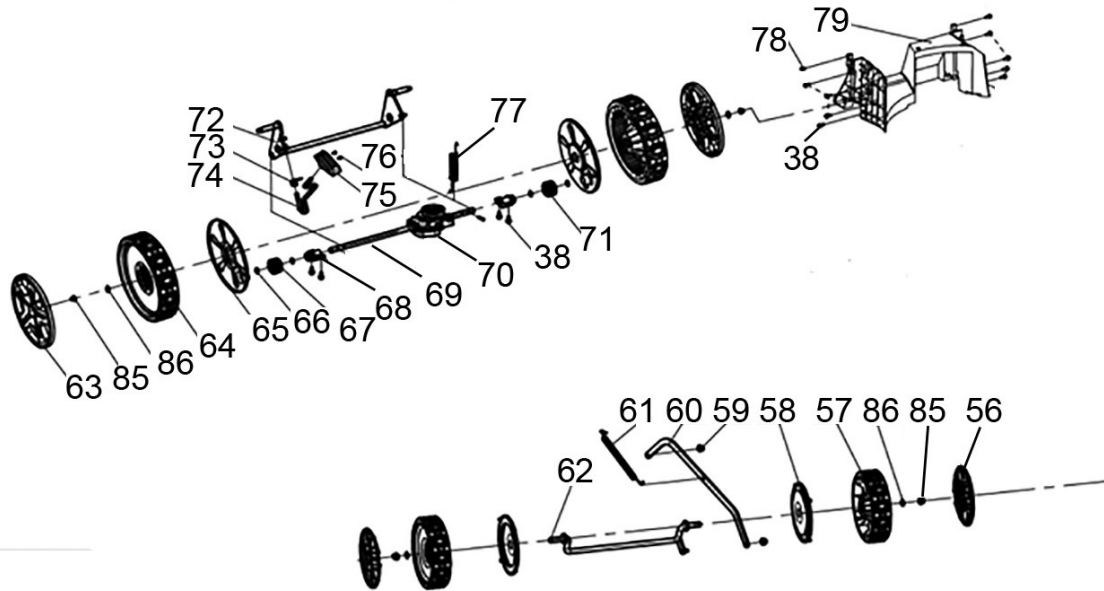

|    |                         |
|----|-------------------------|
| 56 | 8" Wheel cover          |
| 57 | 8" wheel                |
| 58 | Anti-dust wheel cover   |
| 59 | Locking nut             |
| 60 | Connecting lever        |
| 61 | Connecting lever spring |
| 62 | Front axle              |
| 63 | 10" Wheel cover         |
| 64 | 10" Drive wheel         |
| 65 | Anti-dust wheel cover   |
| 66 | Shaft retaining ring    |
| 67 | Driven gear (right)     |

|    |                              |
|----|------------------------------|
| 68 | Rear wheel protective sleeve |
| 69 | Cylinder pin                 |
| 70 | Gearbox assembly             |
| 71 | Driven gear (left)           |
| 72 | Rear axle                    |
| 73 | Height adjustment spring     |
| 74 | Height adjustment lever      |
| 75 | Height adjustment handle     |
| 76 | Cross recessed bolt          |
| 77 | Gearbox spring               |
| 78 | Hex flange st screw          |
| 79 | Rear air duct                |

# COMPONENT SUB ASSEMBLIES

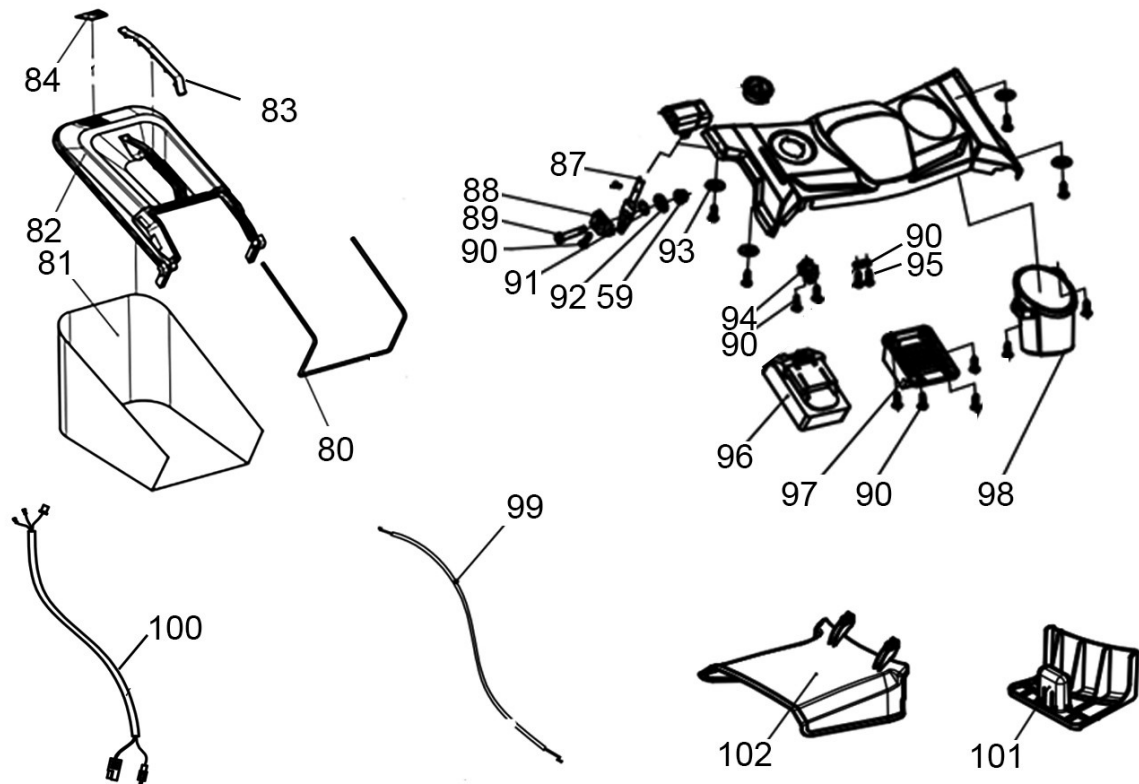

|    |                              |
|----|------------------------------|
| 80 | Grass catcher frame          |
| 81 | Grass catcher bag            |
| 82 | Grass catcher plastic cover  |
| 83 | Cover handle                 |
| 84 | Catcher Full indicator plate |
| 85 | Locknut                      |
| 86 | Flat washer                  |
| 87 | Throttle handle lever        |
| 88 | Throttle handle holder       |
| 89 | Hex bolt M6x16               |
| 90 | Hex self tapping bolt        |
| 91 | Corrugated packing ring      |

|     |                     |
|-----|---------------------|
| 92  | Flat washer         |
| 93  | Flat washer         |
| 94  | Throttle cable seat |
| 95  | Wire holder         |
| 96  | Battery             |
| 97  | Battery holder      |
| 98  | Cup holder          |
| 99  | Throttle cable      |
| 100 | Control wire        |
| 101 | Blanking Plate      |
| 102 | Side discharge duct |
| 103 | Battery charger     |

# ENGINE COMPONENT

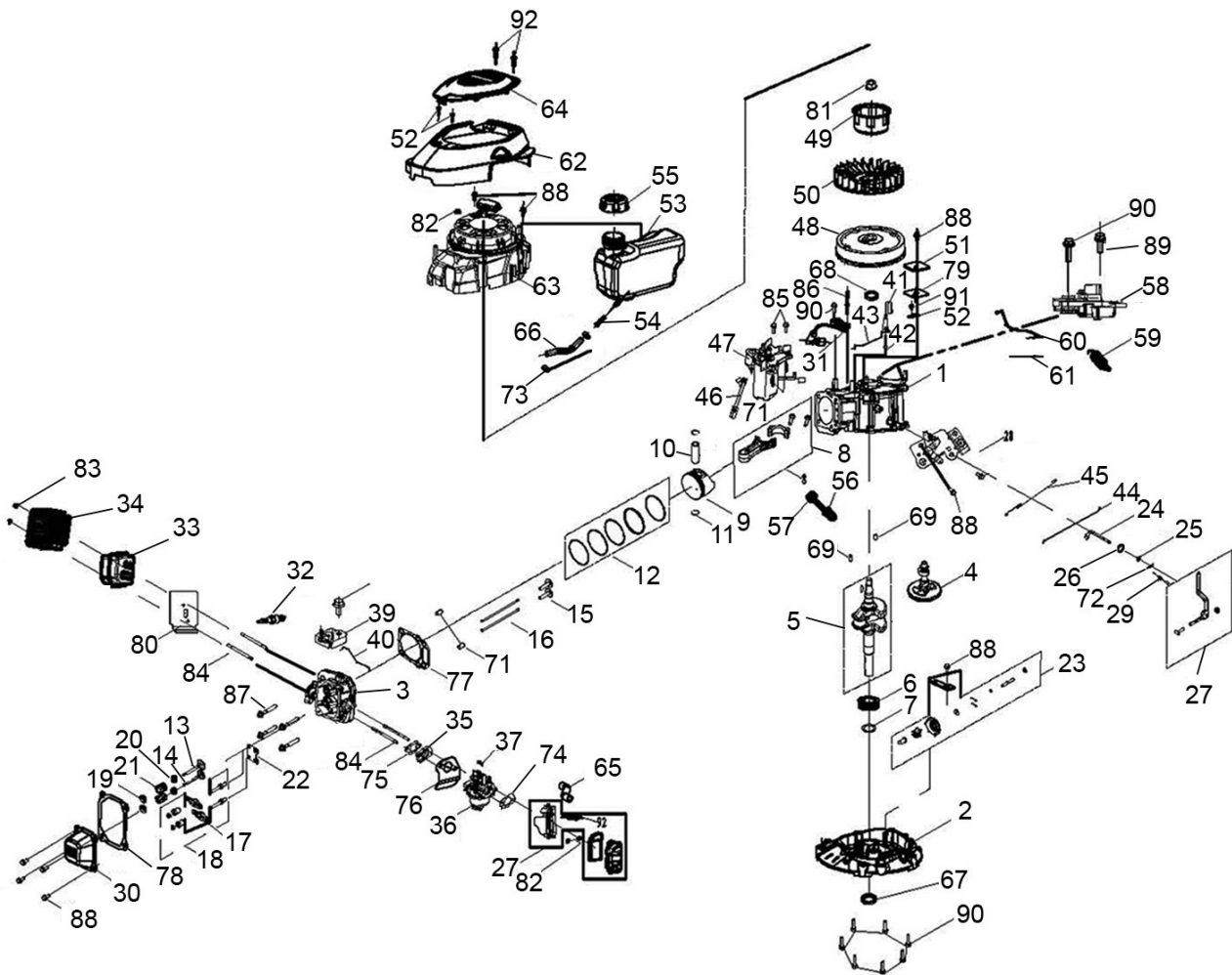

|    |                         |
|----|-------------------------|
| 1  | Crankcase               |
| 2  | Crankcase cover         |
| 3  | Cylinder head           |
| 4  | Camshaft                |
| 5  | Crankshaft              |
| 6  | Crankshaft timing gear  |
| 7  | Washer                  |
| 8  | Connecting rod assembly |
| 9  | Piston                  |
| 10 | Gudgeon Pin             |
| 11 | Circlip                 |
| 12 | Piston ring set         |

|    |                           |
|----|---------------------------|
| 47 | Starter motor             |
| 48 | Flywheel                  |
| 49 | Starting cup              |
| 50 | Impeller                  |
| 51 | Fuel return chamber cover |
| 52 | Breathing valve plate     |
| 53 | Fuel tank                 |
| 54 | Fuel tank filter          |
| 55 | Fuel filler cap           |
| 56 | Oil ruler guide pipe      |
| 57 | Oil ruler                 |
| 58 | Brake assembly            |

|    |                           |
|----|---------------------------|
| 13 | Inlet valve               |
| 14 | Exhaust valve             |
| 15 | Tappet                    |
| 16 | Pushrod                   |
| 17 | Rocker arm                |
| 18 | Valve adjustment bolt     |
| 19 | Inlet spring seat         |
| 20 | Valve oil seal            |
| 21 | Valve spring              |
| 22 | Limit plate               |
| 23 | Governor gear assembly    |
| 24 | Governor arm              |
| 25 | Oil seal                  |
| 26 | Governor arm washer       |
| 27 | Governor support          |
| 28 | Throttle assembly         |
| 29 | Governor spring A         |
| 30 | Cylinder head cover       |
| 31 | Ignitor                   |
| 32 | Spark plug                |
| 33 | Muffler                   |
| 34 | Muffler cover             |
| 35 | Heat insulation plate     |
| 36 | Carburetor assembly       |
| 37 | Lever clip                |
| 38 | Air cleaner               |
| 39 | Thermo-switch             |
| 40 | Temperature control lever |
| 41 | Impeller rotator          |
| 42 | Bolt M6x13                |
| 43 | Impeller lever            |
| 44 | Throttle lever            |
| 45 | Governor spring B         |
| 46 | Battery cables            |

|    |                               |
|----|-------------------------------|
| 59 | Brake spring                  |
| 60 | Shut-down wire                |
| 61 | Grounding wire                |
| 62 | Starter cover                 |
| 63 | Recoil starter small cover    |
| 64 | Cover panel                   |
| 65 | Exhaust pipe                  |
| 66 | Fuel hose                     |
| 67 | Oil seal                      |
| 68 | Oil seal                      |
| 69 | Crankcase location pin 8 x 14 |
| 70 | Locating pin 8*12             |
| 71 | Hollow locating pin           |
| 72 | Cotter pin                    |
| 73 | Spring retaining ring         |
| 74 | Air cleaner gasket            |
| 75 | Intake gasket                 |
| 76 | Carburetor gasket             |
| 77 | Cylinder head gasket          |
| 78 | Cylinder head cover gasket    |
| 79 | Fuel return chamber cover     |
| 80 | Exhaust gasket                |
| 81 | Nut M14                       |
| 82 | Nut M6                        |
| 83 | Nut                           |
| 84 | Intake stud bolt M6x90        |
| 85 | Hex bolt                      |
| 86 | Stud bolt                     |
| 87 | Bolt M8                       |
| 88 | Hex bolt M6 x 12              |
| 89 | Hex bolt M6 x 16              |
| 90 | Hex bolt M6 x 30              |
| 91 | Pan head screw                |
| 92 | Pan head screw                |

# DECLARATIONS OF CONFORMITY- UK



## DECLARATION OF CONFORMITY

This is an important document and should be retained.

We hereby declare that this product(s) complies with the following legislation: The following standards have been applied to the product(s):

|            |  |   |
|------------|--|---|
| 2000/14/EC | Outdoor Noise Directive  | EN ISO 5395-1:2013+A1, EN ISO 3744:1995, ISO 11094:1991 |
| 2006/42/EC | Machinery Directive  |   |
| 2016/1628  | Particulate Emission and Type-Approval for Non-Road Mobile Machinery |   |
| 2011/65/EU | Restriction of Hazardous Substances (RoHS) Directive                 |   |

The technical documentation required to demonstrate that the product(s) meet(s) the requirement(s) of the aforementioned legislation has been compiled and is available for inspection by the relevant enforcement authorities.

The UKCA mark was first applied in: 2025

|                             |   |                              |   |
|-----------------------------|---|------------------------------|---|
| <b>Manufacturer:</b>        | Clarke International Ltd, Hemmall Street, Epping, Essex, CM16 4LG, United Kingdom | <b>Notified Body:</b>        | TÜV Rheinland LGA Products GmbH (ID: 0197), Tillystraße 2, 90431 Nürnberg, Germany                            |
| <b>Product Description:</b> | Lawnmower   | <b>Assessment Procedure:</b> | Annex VI of above noise legislation   |
| <b>Model Number(s):</b>     | CSP56LME  | <b>Measured LWA:</b>         | 97.26 dB  |
| <b>Serial/Batch Number:</b> | Refer to product/packaging label  | <b>Guaranteed LWA:</b>       | 98 dB   |
| <b>Document Holder:</b>     | Alan Pond   | <b>Signed:</b>               | <br>J.A Clarke<br>Director |
| <b>Date of Issue:</b>       | 17/11/2025  |                              |   |

# DECLARATIONS OF CONFORMITY - CE

# CE

# Clarke<sup>®</sup> INTERNATIONAL

## DECLARATION OF CONFORMITY

This is an important document and should be retained.

**We hereby declare that this product(s) complies with the following legislation: The following standards have been applied to the product(s):**

|            |  |   |
|------------|--|---|
| 2000/14/EC | Outdoor Noise Directive  | EN ISO 5395-1:2013+A1, EN ISO 3744:1995, ISO 11094:1991 |
| 2006/42/EC | Machinery Directive  |   |
| 2016/1628  | Particulate Emission and Type-Approval for Non-Road Mobile Machinery |   |
| 2011/65/EU | Restriction of Hazardous Substances (RoHS) Directive                 |   |

The technical documentation required to demonstrate that the product(s) meet(s) the requirement(s) of the aforementioned legislation has been compiled and is available for inspection by the relevant enforcement authorities.

The CE mark was first applied in: 2025

|                             |  |                              |   |
|-----------------------------|--|------------------------------|---|
| <b>Manufacturer:</b>        | Clarke International Ltd, Fitzwilliam Hall, Fitzwilliam Place, Dublin 2, Republic of Ireland | <b>Notified Body:</b>        | TÜV Rheinland LGA Products GmbH (ID: 0197), Tillystraße 2, 90431 Nürnberg, Germany                            |
| <b>Product Description:</b> | Lawnmower  | <b>Assessment Procedure:</b> | Annex VI of above noise legislation   |
| <b>Model Number(s):</b>     | CSP56LME   | <b>Measured LWA:</b>         | 97.26 dB  |
| <b>Serial/Batch Number:</b> | Refer to product/packaging label   | <b>Guaranteed LWA:</b>       | 98 dB   |
| <b>Document Holder:</b>     | Alan Pond  | <b>Signed:</b>               | <br>J.A Clarke<br>Director |
| <b>Date of Issue:</b>       | 17/11/2025   |                              |   |

CSP56LME CE Clarke DOC 111725

Page 1 of 1

# A SELECTION FROM THE VAST RANGE OF

# Clarke®

## QUALITY PRODUCTS



**AIR COMPRESSORS**  
From DIY to industrial, Plus air tools, spray guns and accessories.

**GENERATORS**  
Prime duty or emergency standby for business, home and leisure.

**POWER WASHERS**  
Hot and cold, electric and engine driven - we have what you need

**WELDERS**  
Mig, Arc, Tig and Spot.  
From DIY to auto/industrial.

**METALWORKING**  
Drills, grinders and saws for DIY and professional use.

**WOODWORKING**  
Saws, sanders, lathes, mortisers and dust extraction.

**HYDRAULICS**  
Cranes, body repair kits, transmission jacks for all types of workshop use.

**WATER PUMPS**  
Submersible, electric and engine driven for DIY, agriculture and industry.

**POWERTOOLS**  
Angle grinders, cordless drill sets, saws and sanders.

**STARTERS/CHARGERS**  
All sizes for car and commercial use.



## PARTS & SERVICE: 0208 988 7400

**Parts Enquiries**  
[Parts@clarkeinternational.com](mailto:Parts@clarkeinternational.com)

**Servicing & Technical Enquiries**  
[Service@clarkeinternational.com](mailto:Service@clarkeinternational.com)

SALES: UK 01992 565333 or Export 00 44 (0)1992 565335

**Clarke® INTERNATIONAL** Hemnall Street, Epping, Essex CM16 4LG  
[www.clarkeinternational.com](http://www.clarkeinternational.com)